

**Data sheet: 325544**  
**Item no. 325544**  
**I52 Valve head type N, pneumatic actuator with lever handle.**  
**PTFE membrane (TFM 1600)**

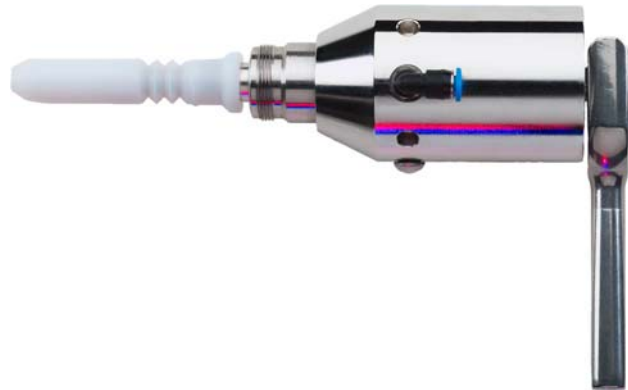

Available with:



Silicone membrane  
Item no.: 320051  
See 320044



EPDM membrane  
Item no.: 320052  
See 320044



PTFE membrane  
Item no.: 320055  
See 325544

Valve body Type I  
Item no.: 320002

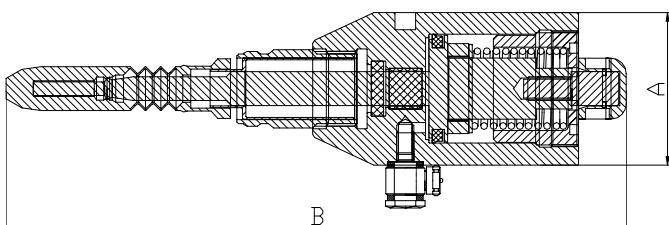
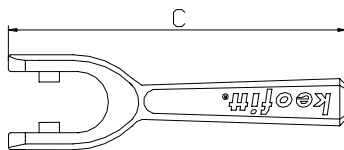
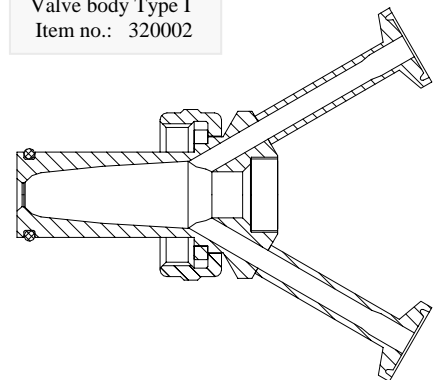

Where to use :

How to use:

Installation:

Open / Close indication:

**Material:**

Steel Parts:

Membrane

**Key measurements**

Drawing part A:

Drawing part B:

Drawing part C:

Net weight:

Temp. range:

Product pressure range:

Air supply pressure range:

With Valves bodies I52

Pneumatically and manually operated

Screwed in Valve body

Proximity (option)

AISI 304 / 316 / 316L(1.4404)

FDA approved PTFE

Ø45 mm.                      Ø1.77 In.

183 mm.                      7.2 In.

99.5 mm.                      3.92 In.

1.1 kg./pc                      2.43 lb

1<sup>0</sup>C - 150<sup>0</sup>C                      34°F - 302°F

0 - 6 bar(g)                      0 - 87 psi(g)

4 - 7 bar(g)                      58 - 101 psi(g)